

## COMPONENTS

### DISK BRAKES

All Stromer models are equipped with hydraulic disk brakes. Brake performance is adapted to the high speed and the higher weight of the modular e-bikes.

### TIRES

For increased safety, the Stromer is equipped with tires with integrated puncture protection. The Schwalbe BigBen tire developed especially for Stromer offers increased shock absorption for the most comfortable ride.

### FORK

Impacts and vibrations are minimized by the light Stromer carbon fork. Thanks to the high level of comfort, cycling fun is guaranteed.

COMPONENTS	ELITE	PLATINUM
Gearshift	Shimano Sora	Shimano Sora XT
Front derailleur		Shimano Sora
Shifters	Shimano Sora	Shimano Sora
Gear speeds	9	27
Brakes	Magura MT2	Magura MT2
Rear cogs	11-32	11-32
Crank	Single 42T by Mountain 33 / S 52T by Power 48	FSA Tempo 30/39/50
Saddle	Stromer	Stromer
Pedals	Wellgo normal	Wellgo normal



## DESIGN AND ACCESSORIES

### CITY KIT

- Front light B+M Lumotec IQ Fly Stromer
- Rear light B+M Toplight mini
- Kickstand Pletscher Optima
- Mudguards Stromer
- Carrier Tubus Stromer Racktime System

### CITY KIT PLATINUM

- Front light Supernova E3 Stromer
- Rear light B+M Toplight mini
- Kickstand Pletscher Optima
- Mudguards Stromer
- Carrier Tubus Stromer Racktime System

### STROMER RECOMMEND:

- + Additional charger Stromer
- + Additional battery Stromer 396 Wh (36 V, 11 Ah)
- + Additional battery Stromer 522 Wh (36 V, 14.5 Ah)
- + Carrier Tubus Stromer Racktime System
- + e-bike Rearview mirror
- + Bell
- + Pants protector ring
- + Foldable lock Trelock FS300
- + Racktime system adapter Snapit
- + Racktime lock Secureit
- + Trailer plate Stromer



## POWER SYSTEM

The Stromer is powered by the rider and a brushless direct-current motor in the rear hub. A high degree of system efficiency can be achieved because the motor acts directly within the rear hub. The only mechanical contact that occurs within the motor is the industrial ball bearings. The motor is virtually maintenance free. The Stromer motor is available in three versions:

MOTOR	MOUNTAIN 25	MOUNTAIN 33*	POWER 48*
Supported speed	Up to 25 km/h	Up to 33 km/h	Up to 45 km/h
Output	250 W**	500 W	500 W
Torque	20 Nm**	40 Nm	30 Nm
Range (with ST522 battery)***	40-100 km	40-90 km	40-80 km

\* Depending on the country, you may need insurance and/or need to obtain a license plate \*\* 500 W / 40 Nm in Switzerland  
\*\*\* Sensor sensitivity 3, rider 70 kg

### MOUNTAIN 25 – SMOOTH AND STRONG.

Suitable for relaxing rides in the country or the city.

### MOUNTAIN 33 – FOR STEEP TERRAIN.

For trailers. For child bike trailers.

### POWER 48 – HIGHEST SPEED.

Suitable for almost any topography.

### BATTERY

The battery integrated into the frame is an energy package. At a low weight of 3 kg, it offers 396 Wh or optionally 522 Wh of power.

BATTERY	ST396	ST522
Energy	396 Wh	522 Wh
Voltage	36V	36V
Capacity	11 Ah	14.5 Ah
Weight	3 kg	3 kg

## FORK OPTION

+ Suspension fork SR Suntour Ridon Stromer

## FRAME COLOR

The Stromer is available in three basic color variants:

Red, White or Black.



# heartbeat



## FRAME SIZE

### STROMER MEN

Body size	Frame size	A	B	C	D	E	F	G	H
to 175cm	16.5"	420*	585*	205*	74.5°	70°	425*	415*	-57*
from 175cm	20	508*	585*	205*	74.5°	70°	425*	415*	-57*

### STROMER LADY

Body size	Frame size	A	B	C	D	E	F	G	H
to 175cm	16.5"	420*	580*	235*	74.5°	70°	425*	415*	-57*

\* in mm

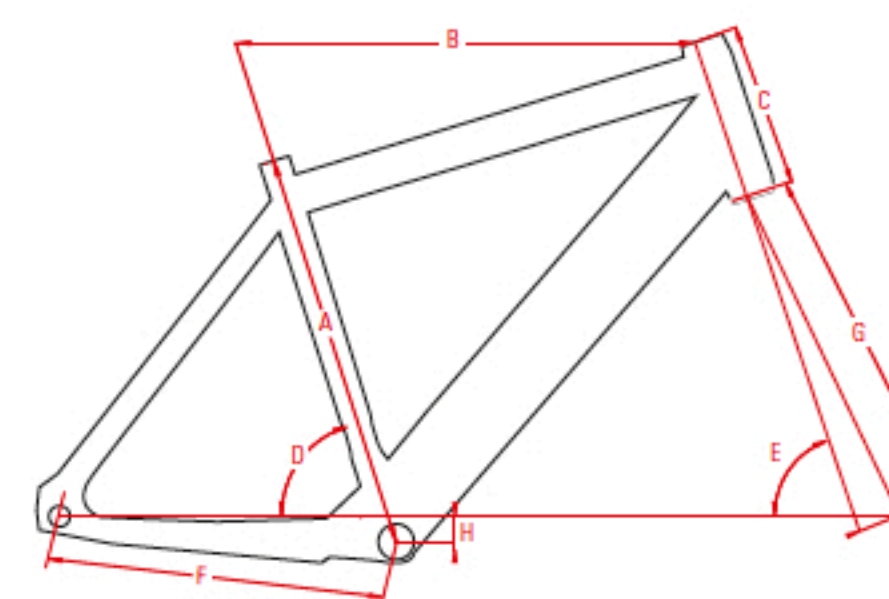

Stromer Men

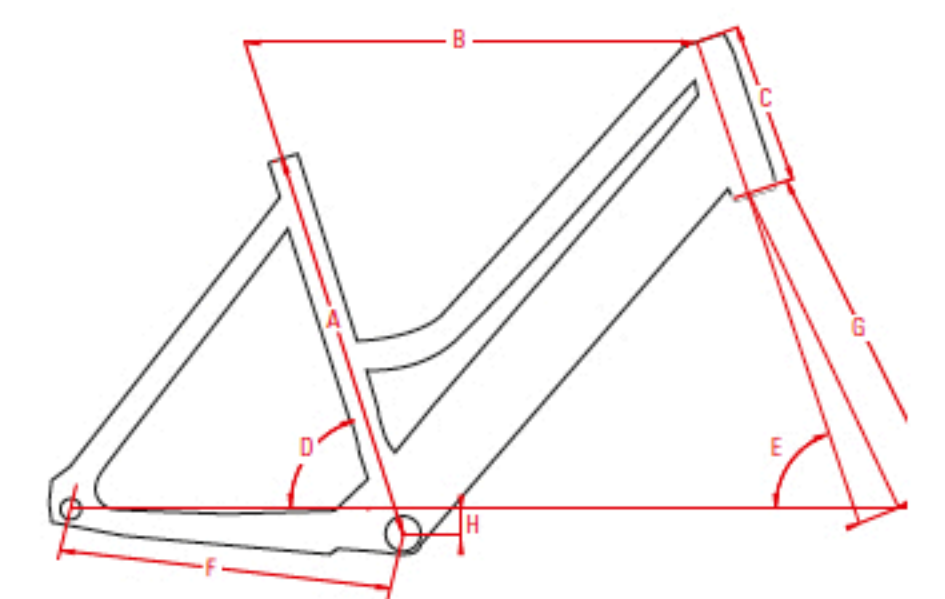

Stromer Lady

# freedom